

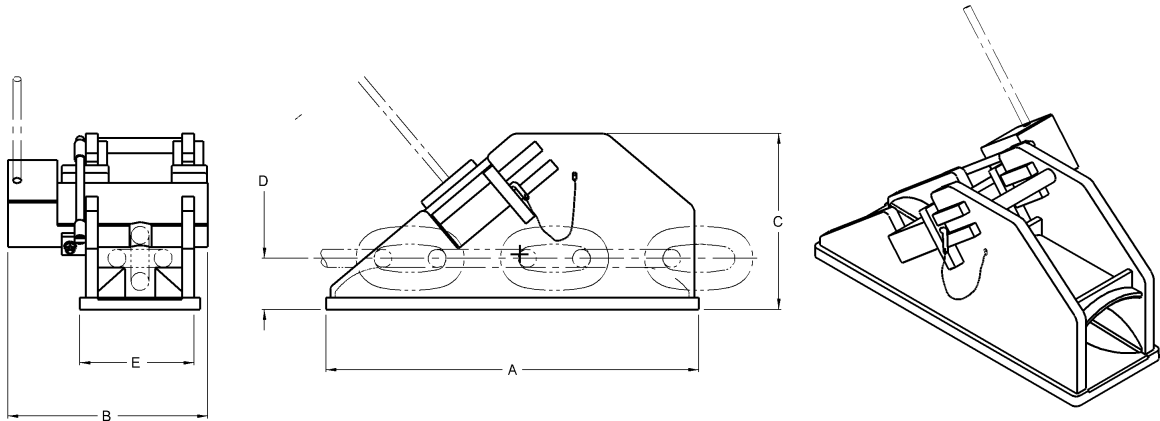

Bar Type Chain Stoppers



<i>Model Number</i>	<i>Units of Measure</i>	<i>Maximum Chain Size</i>	<i>Chain Breaking Strength</i>	<i>A</i>	<i>B</i>	<i>C</i>	<i>D</i>	<i>Weight</i>
CS-40-S	Inches	2- 1/2	692,000 lbs	42	35- 1/2	22-40/63	7- 1/4	1700 lbs
	MM	64	3078 kN	1067	902	575	184	771 Kg
CS-48-S	Inches	3	1,000,000 lbs	62	33- 1/4	29- 1/4	9- 3/16	3510 lbs
	MM	76	4448 kN	1575	845	743	233	1592 Kg

Standard Features

- Designed for breaking strength of chain
- Manual operation
- Grease lubricated bronze bearings
- Weld down base
- Heavy duty steel construction
- Smith Berger Quality

Optional Features

- Other sizes available
- Bolt down base
- Third party certification
- Hydraulic / pneumatic operation
- Paint to your specification
- OCIMF designs
- Load monitoring system

We will custom engineer any of our products to suit YOUR requirements!