

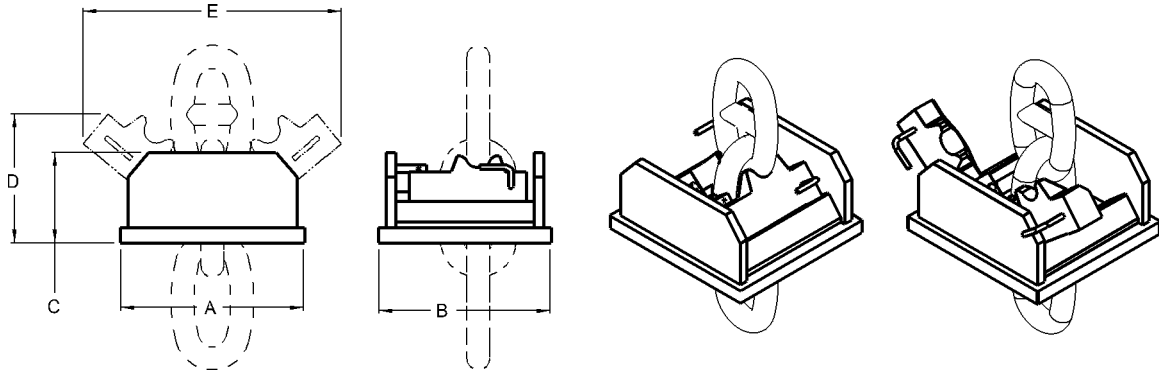

Dual Pawl Type Chain Stoppers Vertical Lead



Model Number	Units of Measure	Maximum Chain Size	Chain Breaking Strength	A	B	C	D	E	Weight
CS-48-DP	Inches	3	970,000 lbs	24	22- 1/2	11- 3/4	16- 1/2	33- 1/2	692 lbs
	MM	76	4315 kN	610	572	298	419	851	314 Kg
CS-64-DP	Inches	4	1,632,000 lbs	32	30	15- 3/4	22- 1/4	44- 3/4	925 lbs
	MM	102	7260 kN	813	762	400	565	1137	420 Kg
CS-80-DP	Inches	5	3,317,000 lbs	40	37- 1/2	19- 5/8	28	56	1160 lbs
	MM	127	14,755 kN	1016	953	498	711	1422	526 Kg

Standard Features

- Designed for breaking strength of chain
- Dual pawl design reduces contact stress in chain
- Manual operation
- Weld down base
- Smith Berger Quality

Optional Features

- Other sizes available
- Bolt down base
- Third party certification
- Hydraulic / pneumatic operation
- Paint to your specification
- Load monitoring system

*We will custom engineer any of our products to suit **YOUR** requirements!*

7915 10th Ave. S., Seattle, WA 98108 USA - Tel: 206-764-4650 - Fax: 206-764-4653 - Website: www.SmithBerger.com