

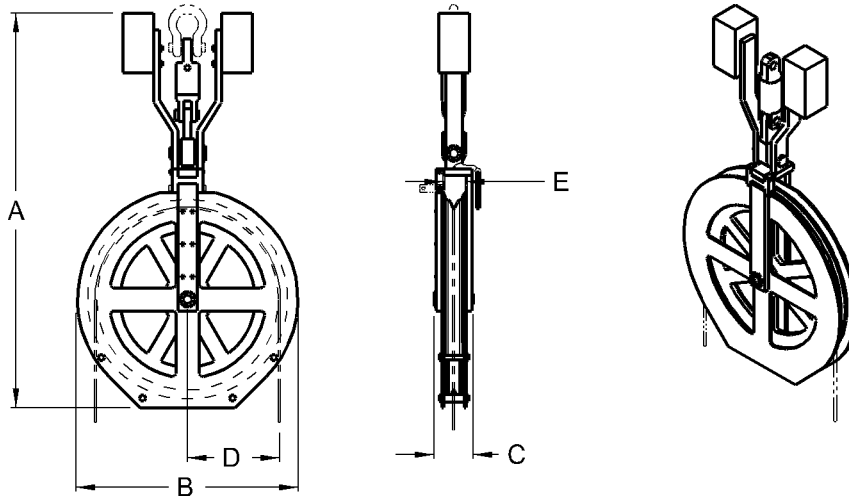

Oceanographic Hanging Snatch Blocks



Model Number	Units of Measure	Maximum Wire Size	Wire Breaking Strength	Sheave Tread Diameter	A	B	C	D	E	Weight
22-NC	Inches	3/8"	14,800 lbs	19- 5/8	55- 3/4	25	9- 1/2	10	5- 3/4	500 lbs
	MM	19	66 kN	498	1416	635	241	254	146	227Kg
52-NC	Inches	3/4"	57,000 lbs	47- 1/4	102- 5/8	57- 3/8	10- 3/4	24	5- 3/4	1700 lbs
	MM	25	254 kN	1200	2607	1457	273	610	146	771 Kg

Standard Features

- Designed for breaking strength of wire at 135° wrap on the sheave
- Nylatron sheaves are ideal for use with wire rope, electro-mechanical or fiber optic cables
- Sealed grease lubricated Timken tapered roller bearings
- Wide throat allows for passage of wire end fittings and connectors
- Adjustable counterweights
- Heavy duty swivel

Optional Features

- Steel sheaves
- Third party certification
- Other sizes available
- Paint to your specification
- Load monitoring system

*We will custom engineer any of our products to suit **YOUR** requirements!*

7915 10th Ave. S., Seattle, WA 98108 USA - Tel: 206-764-4650 - Fax: 206-764-4653 - Website: www.SmithBerger.com