

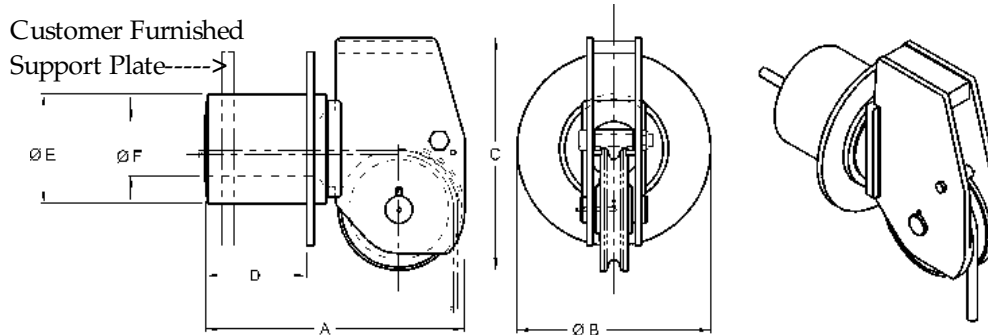

# Flange Mounted Balanced Head Fairleads



Model Number	Units of Measure	Maximum Wire Size	Wire Breaking Strength	Sheave Tread Diameter	A	B	C	D	E	F	Weight
MD-710	Inches	3/4	58,800 lbs.	8- 1/4	21- 7/16	16	19- 1/8	8- 3/8	9	4- 1/2	255 lbs.
	MM	19	262 kN	210	545	406	486	213	229	114	116 Kg
MD-712	Inches	1	103,400 lbs.	9- 3/4	25- 7/16	17	23- 1/8	10- 3/8	11	5- 5/8	363 lbs.
	MM	25	460 kN	248	646	432	587	264	279	143	165 Kg
MD-714	Inches	1- 1/4	159,800 lbs.	11- 1/4	27-11/16	18- 3/4	26- 5/8	10- 5/8	11- 3/4	6- 5/16	560 lbs.
	MM	32	711 kN	286	703	476	676	270	298	160	254 Kg
MD-718	Inches	1- 1/2	228,000 lbs.	14- 1/4	35- 1/8	25	34- 1/4	13- 3/4	16	8- 1/2	1160 lbs.
	MM	38	1014 kN	362	892	635	870	349	406	216	526 Kg
MC-722	Inches	1- 3/4	266,000 lbs.	18- 1/2	42- 1/8	27	43- 1/2	16	18	9- 1/2	1722 lbs.
	MM	44	1183kN	470	1070	686	1105	406	457	241	781 Kg

## Standard Features

- Designed for breaking strength of wire with 90° wrap on sheave and +/- 90° rotation of swivelhead
- Sealed grease lubricated Timken tapered roller bearings
- Hardened rope grooves for longer life
- Weld down mounting flange
- Removable guide roller
- Smith Berger Quality

## Optional Features

- Tail Sheaves /Tail Rollers
- Bolt down mounting flange
- Load monitoring system
- Special sheaves for high performance synthetic ropes
- Paint to your specification
- Third party certification

*We will custom engineer any of our products to suit YOUR requirements!*



# Flange Mounted Balanced Head Fairleads

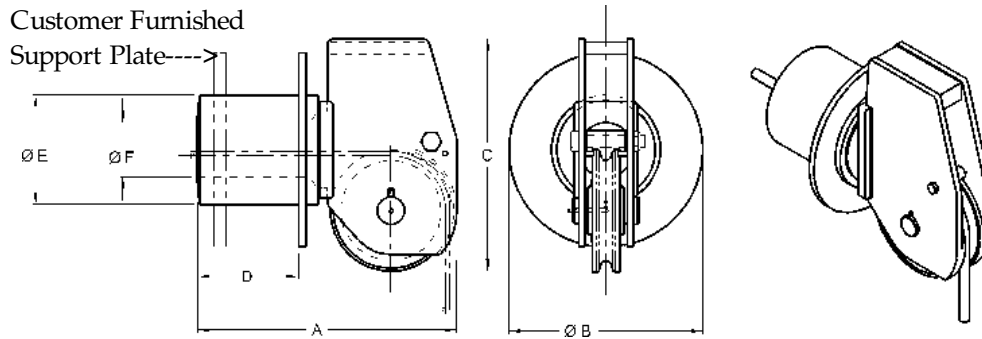

Model Number	Units of Measure	Maximum Wire Size	Wire Breaking Strength	Sheave Tread Diameter	A	B	C	D	E	F	Weight
MC-724	Inches	2	344,000 lbs.	20	47	30	42- 3/4	17- 3/4	20	12	2067 lbs.
	MM	51	1530 kN	508	1194	762	1086	451	508	305	938 Kg
MD-730	Inches	2- 1/4	494,000 lbs.	24- 7/8	53- 7/8	35- 1/2	58- 3/4	22- 1/4	24	13	3936 lbs.
	MM	57	2198 kN	632	1368	902	1492	565	610	330	1785 Kg
MC-736	Inches	2- 1/2	524,000 lbs.	30	59- 1/2	39	68- 1/4	24- 1/4	26	14- 1/2	5100 lbs.
	MM	64	2331 kN	762	1511	991	1734	616	660	368	2313 Kg
MD-752	Inches	3	818,000 lbs.	44	102- 5/8	60	98	41	39- 1/2	26- 1/2	15,400 lbs.
	MM	76	3639 kN	1118	2607	1524	2489	1041	1003	673	7484 Kg
MD-765	Inches	3	818,000 lbs.	55- 1/2	115- 5/8	60	117- 1/2	41	39- 1/2	26- 1/2	17,700 lbs.
	MM	76	3639 kN	1410	2937	1524	2985	1041	1003	673	8029 Kg

## Standard Features

- Designed for breaking strength of wire with 90° wrap on sheave and +/- 90° rotation of swivelhead
- Sealed grease lubricated Timken tapered roller bearings
- Hardened rope grooves for longer life
- Weld down mounting flange
- Removable guide roller
- Smith Berger Quality

## Optional Features

- Tail Sheaves /Tail Rollers
- Bolt down mounting flange
- Load monitoring system
- Special sheaves for high performance synthetic ropes
- Paint to your specification
- Third party certification

*We will custom engineer any of our products to suit YOUR requirements!*