

PROJECT NAME

DRAWING TITLE
MSCN1000 CONE
FENDER

REVISIONS		
REV.	DATE	DESCRIPTION
0	1/28/2024	FOR CONSTRUCTION

DRAWN	CHECKED	APPROVED
RR	JH	AP

SHEET TITLE		
CONE FENDER DETAILS		
PROJECT NUMBER	SHEET SIZE	SCALE
10444	ANSI D	1:7
DRAWING NUMBER	SHEET	
MSCN1000 CONE FENDER	1 OF 4	

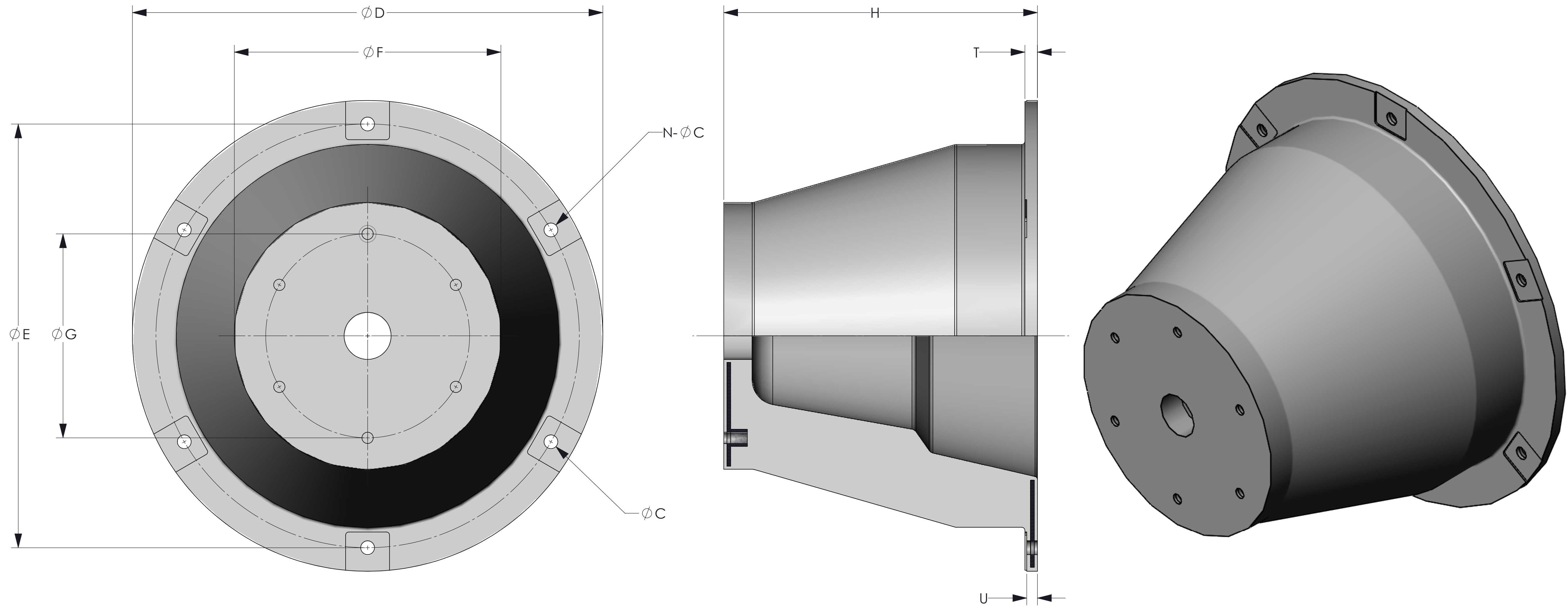

PROJECT NAME

DRAWING TITLE
MSCN1000 CONE
FENDER

REVISIONS

REV.	DATE	DESCRIPTION
0	1/28/2024	FOR CONSTRUCTION

DRAWN	CHECKED	APPROVED
RR	JH	AP

SHEET TITLE

CONE FENDER DETAILS

PROJECT NUMBER	SHEET SIZE	SCALE
10444	ANSI D	1:7

DRAWING NUMBER	SHEET
MSCN1000 CONE FENDER	2 OF 4

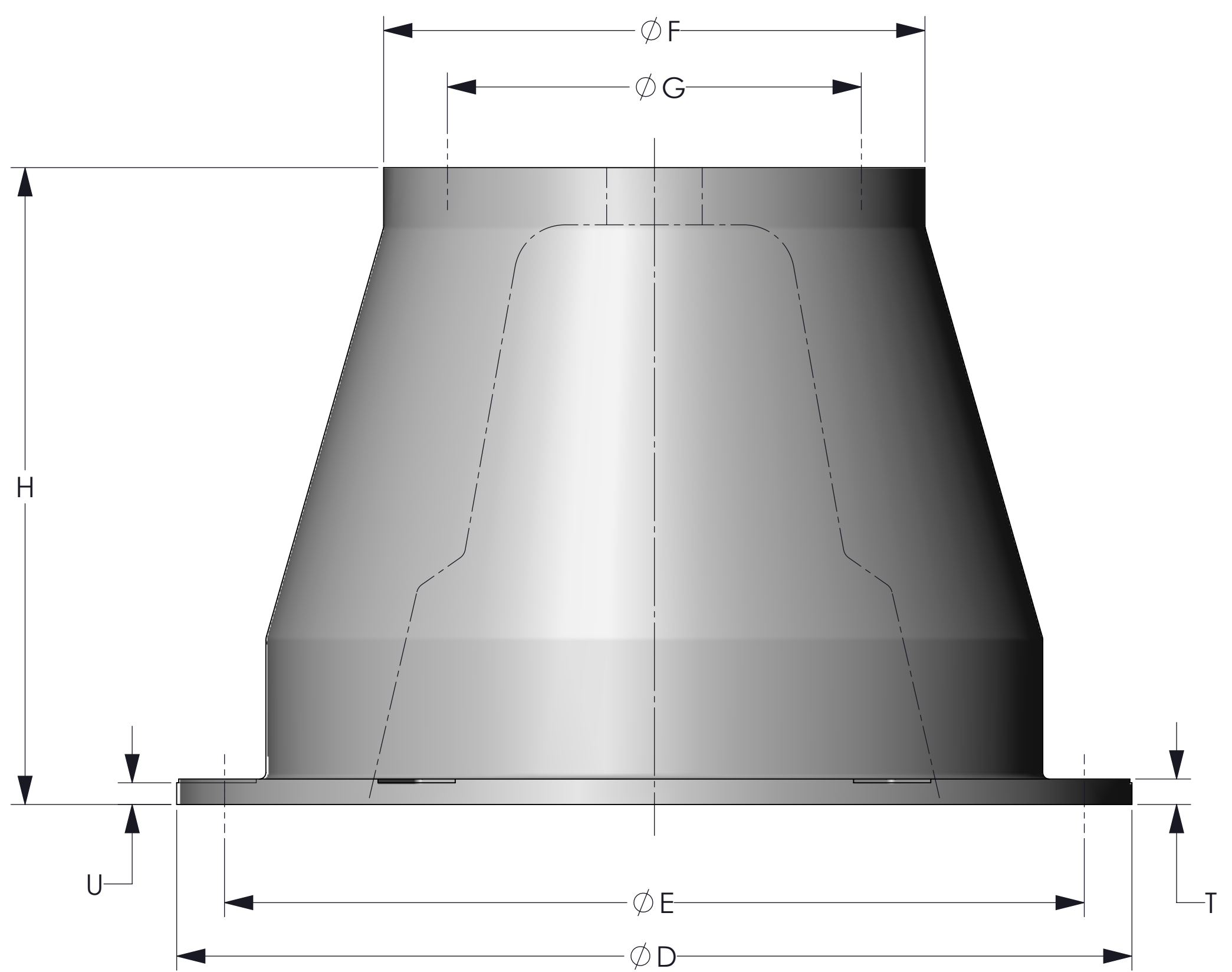
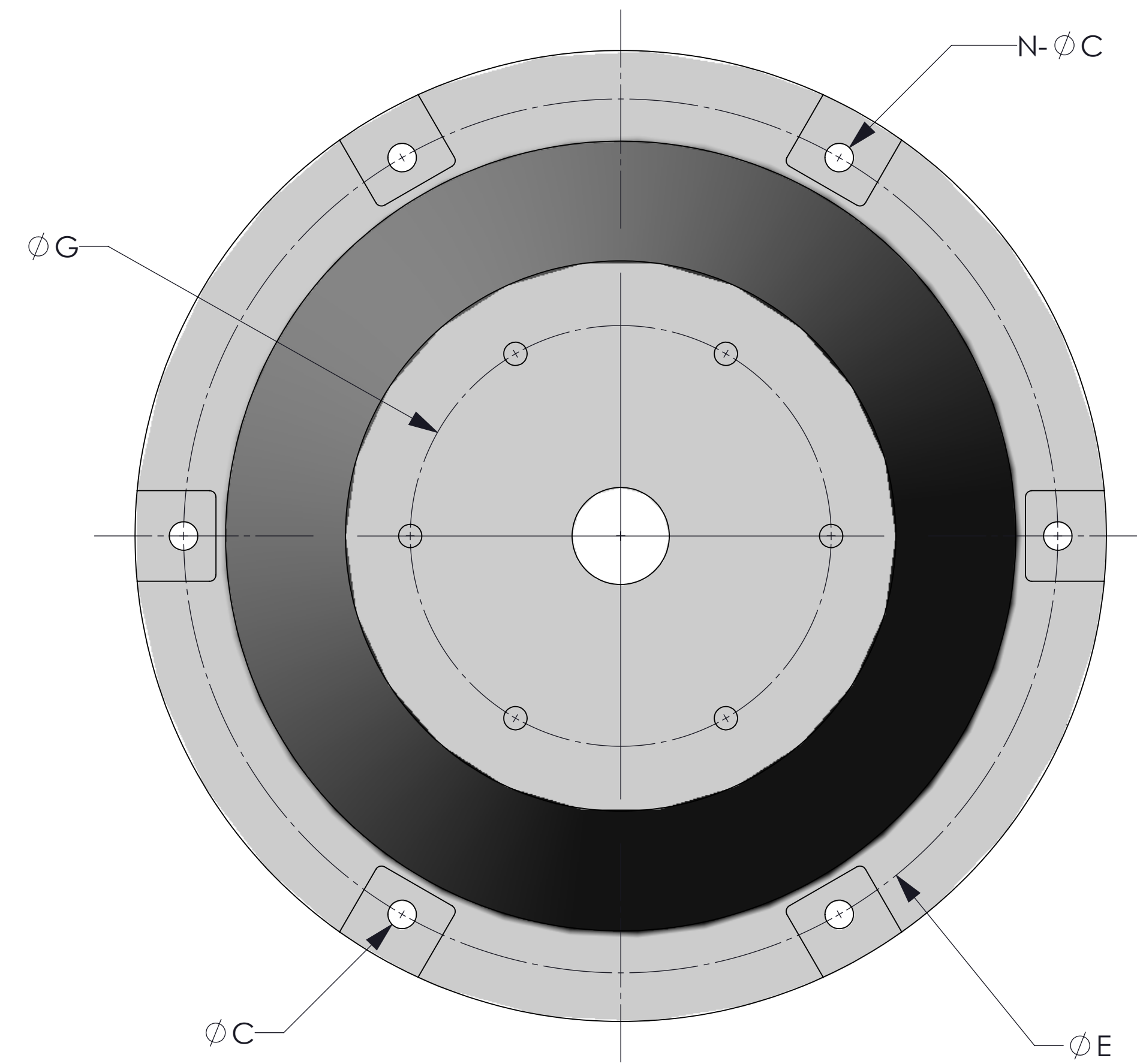
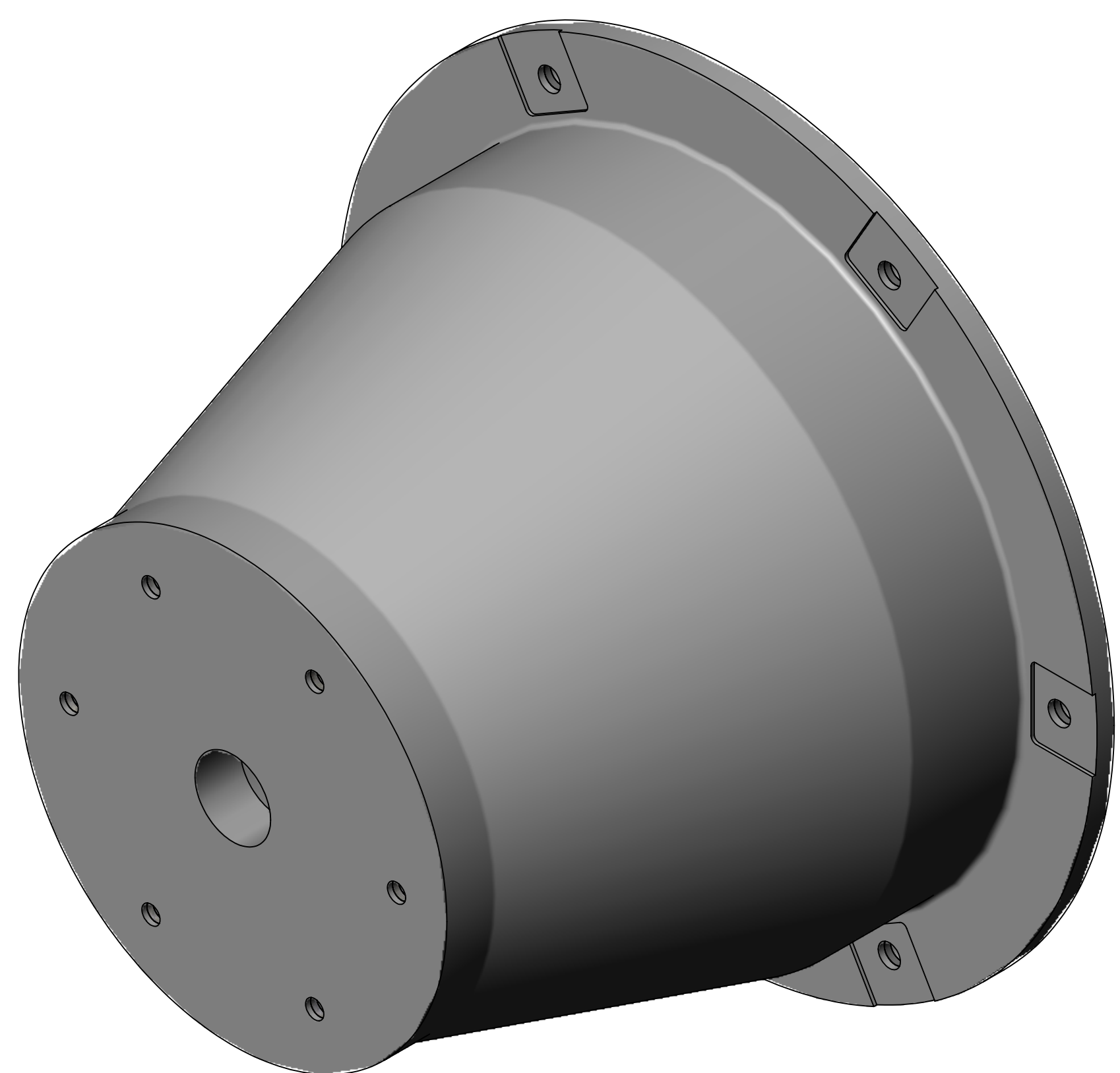

PROJECT NAME

DRAWING TITLE
MSCN1000 CONE
FENDER

REVISIONS		
REV.	DATE	DESCRIPTION
0	1/28/2024	FOR CONSTRUCTION

DRAWN	CHECKED	APPROVED
RR	JH	AP

SHEET TITLE		
CONE FENDER DETAILS		
PROJECT NUMBER	SHEET SIZE	SCALE
10444	ANSI D	1:7
DRAWING NUMBER	SHEET	
MSCN1000 CONE FENDER	3 OF 4	